

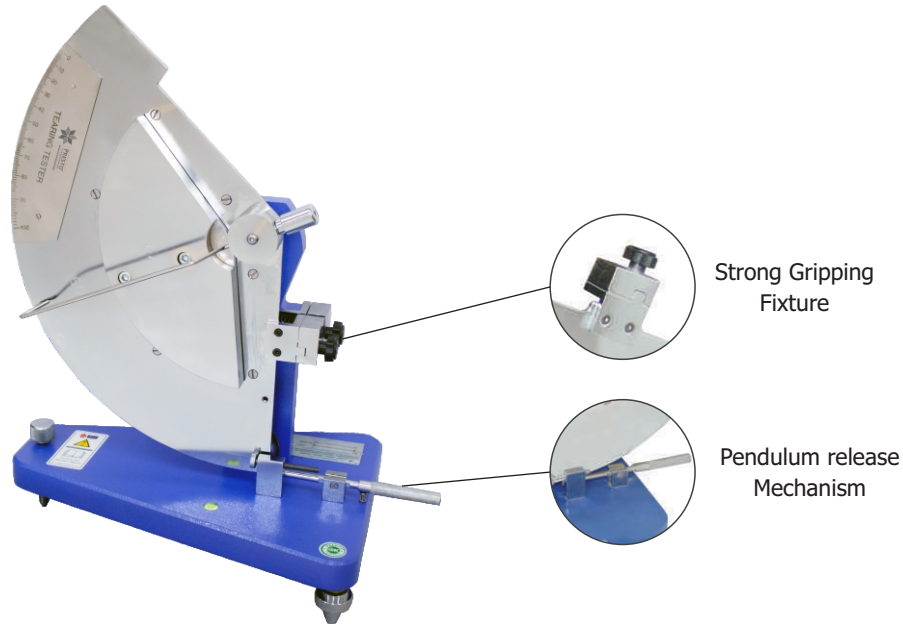

Tearing Strength Tester



Model No.: PTT-156

Tearing Strength Tester is a consistent tool useful to determine the tearing strength of fabrics, plastic films and similar materials. Tearing Strength Tester is the tensile force required to rupture a pre-slit sample under controlled test conditions. PRESTO Tearing Strength Tester is designed as per standards ASTM D1424-09(2013), ASTM D1776, ASTM D689.

- High Quality rugged structure with corrosion resistant main body
- Falling pendulum type instrument
- Single handed hassle free operation
- Highly accurate test results under multiple pendulum weights
- Strong gripping fixture for holding test samples
- Pendulum release mechanism to cover various measuring range
- Inbuilt calibration weights

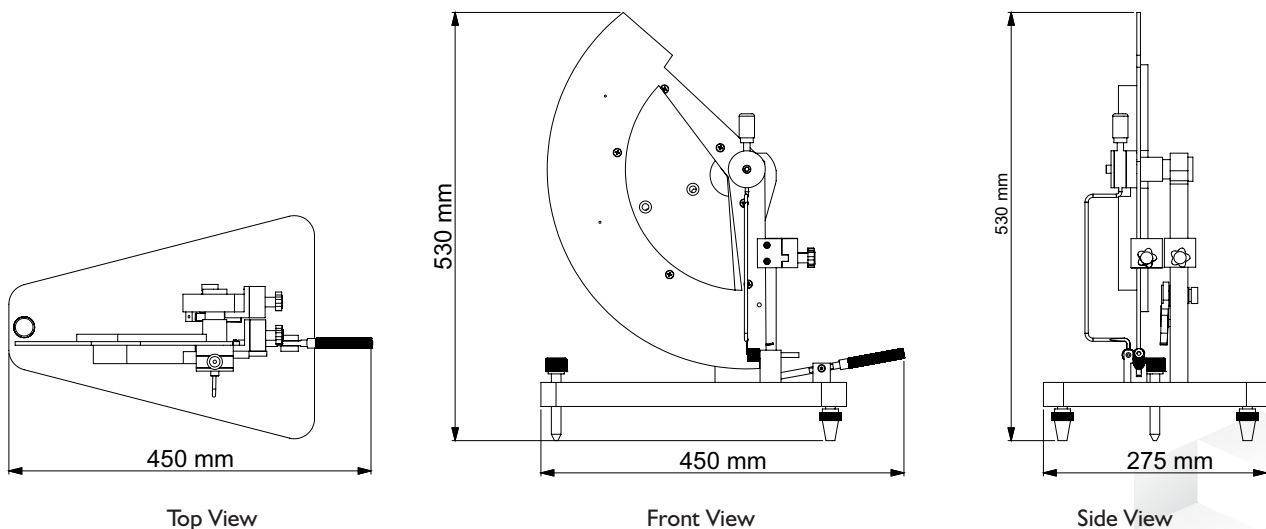



Presto Stantest Pvt. Ltd.

I-42, DLF Industrial Area Phase-1, Delhi Mathura Road, Faridabad 121003, Haryana, India
P : 9210 903 903, +91 129 4272727, 93111 24302 E : info@prestogroup.com

- Faridabad • Sonipat • Kolkata • Mumbai • Pune • Ahmedabad
- Chennai • Bangalore • Hyderabad



www.prestogroup.com

Key Specifications:

Forcefor Pendulum	1600, 3200 & 6400 gm force
Constant Radius of Tear	38 mm
Unit Scale range	0 -
Slit Size	20 mm
Zero	Adjustable Zero Point
Calibration Check weight	At 1600gf, at 3200gf, at 6400gf

Highlights:

Clamps	Flat type
Legs	Adjustable legs
Material of Main Body	Mild Steel
Blades	Single edged

Optional :

- Higher Capacity 12800 gm force on request available.

Thank you customers for choosing us as your partners in growth !



*All the above logos are the sole property of their respective owners and are used purely for depiction purposes only.

OUR OTHER PRODUCTS :-

Box Compression Tester	Scuff Resistance Tester	Tensile Tester Digital	Spectrocolorimeter	Cobb Sizing Tester	Digital GSM Balance

www.prestogroup.com

